

DESCRIPTION

The EC-100M microphone is equipped with an electronic chime.
 It can be operated as easily as normal type microphones, and can be used in any locations.
 The EC-100M's power saving design permits it to be operated for approximately 2 years (on the assumption that it is used 150 times a day) on two R14P batteries. (It is highly recommended that the batteries be replaced every 2 years to avoid battery leakage.)

SPECIFICATIONS

* 0 dB = 1 V

Power Source	3 V DC (R14P × 2)
Current Consumption	2 mA during chime and microphone operation 10 μA at no operation
Chime Tones	4-tone chime (up/down)
Microphone	Unidirectional dynamic type
Microphone Frequency Response	200 Hz - 10 kHz
Output	Chime signal: -45 dB*, 600 Ω, unbalanced (chime volume control set to maximum position) Microphone: -53 dB, 600 Ω, unbalanced (1 kHz, 0 dB = 1 V/Pa)
Finish	Case: Zinc die casting, metallic gold
Weight	770 g
Accessory	Connection cord (2 m)1, Slotted-head screwdriver.....1, Windscreen.....1

Note: Prepare 2 batteries (not supplied with the unit).

APPEARANCE

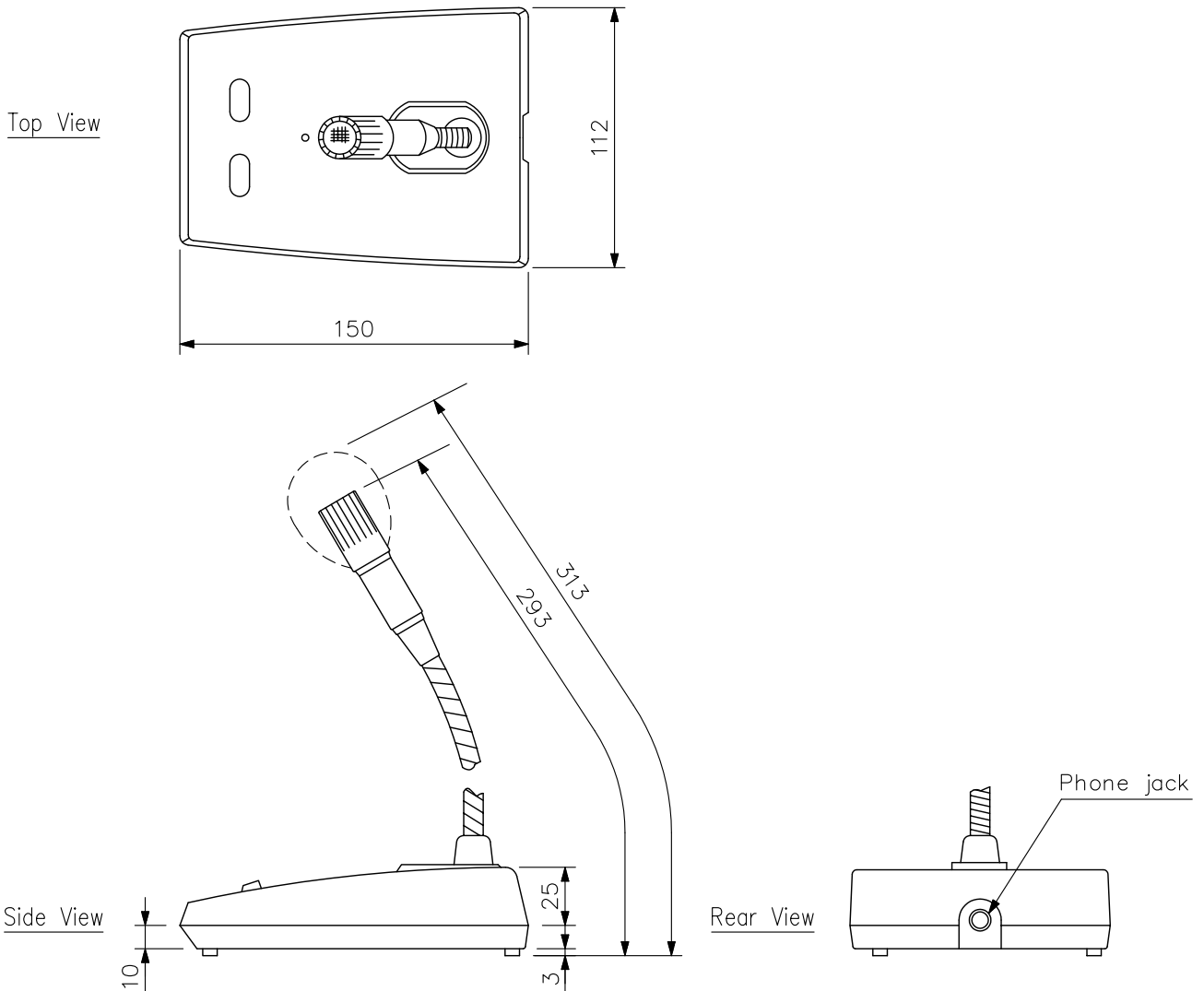

UNIT:mm SCALE:1/3